

Collecting Screw Conveyor

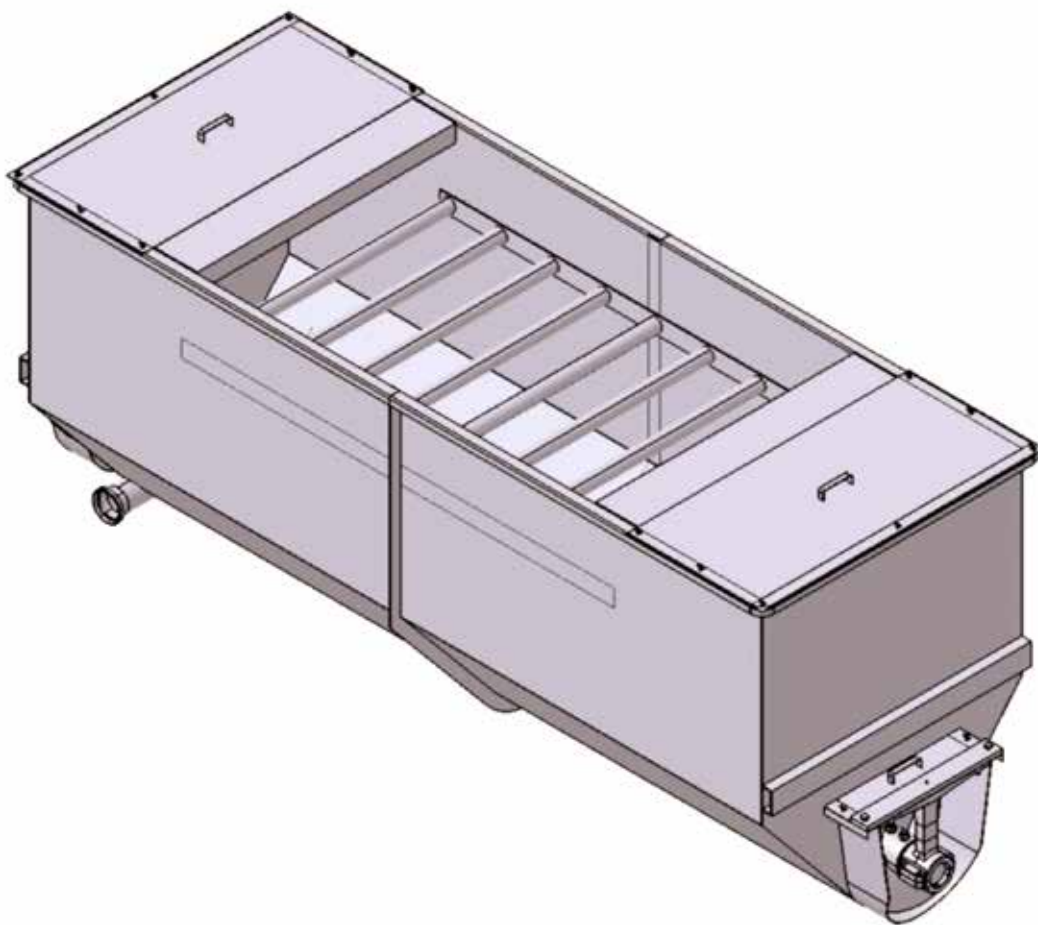

Collecting screw
conveyor for residue
discharge from the
Bucher HPX/HPS press

- Hopper volume sufficient for residue of a press charge
- Fast discharge of the hopper
- Four sizes for 1-4 presses

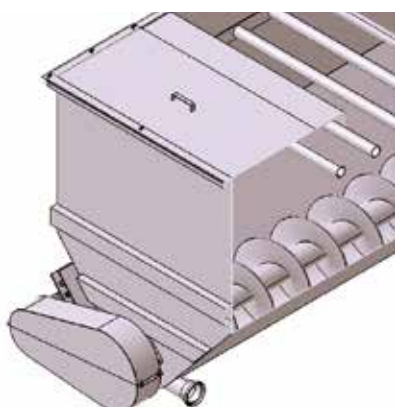

Application

The Delta collecting screw conveyor is designed for removal of the press residue from the Bucher HPX/HPS presses. The hopper volume is sufficient to take the entire residue of a press charge to allow a fast dumping.

Design and functionality

The V-shaped hopper is installed under the steel frame of the Bucher HPX/HPS press. The press dumps the residue into the hopper. It is then

conveyed by a horizontal auger to the intended storage site or to the next transportation element. For safety reasons the hopper is equipped with protective bars below the dumping outlet of the press; the remaining part of the hopper is covered with removable lids. The unit is driven by a gear motor and a chain drive. Construction of the screw in stainless steel in accordance with DIN 1.4301 (AISI 304) or painted mild steel.

Technical data

Delta Collecting Screw Conveyor

	1	2	3	4
Number of presses	1	2	3	4
Screw diameter	400 mm	400 mm	400 mm	400 mm
Hopper length	3'400 mm	7'400 mm	11'400 mm	15'400 mm
Screw speed	25 rpm	25 rpm	25 rpm	25 rpm
Motor 400 V/50 Hz	5.5 kW	11 kW	15 kW	15 kW
Capacity	25 m ³ /h	25 m ³ /h	25 m ³ /h	25 m ³ /h

Bucher Unipektin AG
 Murzlenstrasse 80
 CH-8166 Niederweningen
 Tel. +41 44 857 23 00
 info@bucherunipektin.com
 bucherunipektin.com

Helpdesk
 Tel. +41 44 857 22 22
 service@bucherunipektin.com

Technical support
 Tel. +41 44 857 22 33
 support@bucherunipektin.com

Products and Services

Process technology for fruit and vegetable processing to juices, concentrates and puree production, for brewing solutions, for filtration, for milk powder production, for the vacuum drying of liquid and solid products, for freeze drying of coffee, tea, fruits, vegetable, etc. Technology for municipal and industrial sludge dewatering and drinking water filtration

Products

Fruit reception lines, mills, mash heaters, hydraulic presses, membrane filtration equipment, cold block equipment, adsorber, ion exchanger, evaporators and aroma plants, pasteurizers, CIP systems, vacuum and freeze drying cabinets and belt dryer, zeolite adsorber, complete processing lines

Services

Process development and project engineering; assembly and commissioning; technical support; original spare parts; inspection; service contracts; retrofits; training; service and maintenance; NetService