

Polynox MF

Industrial cross-flow beer filtration
with polymeric membranes

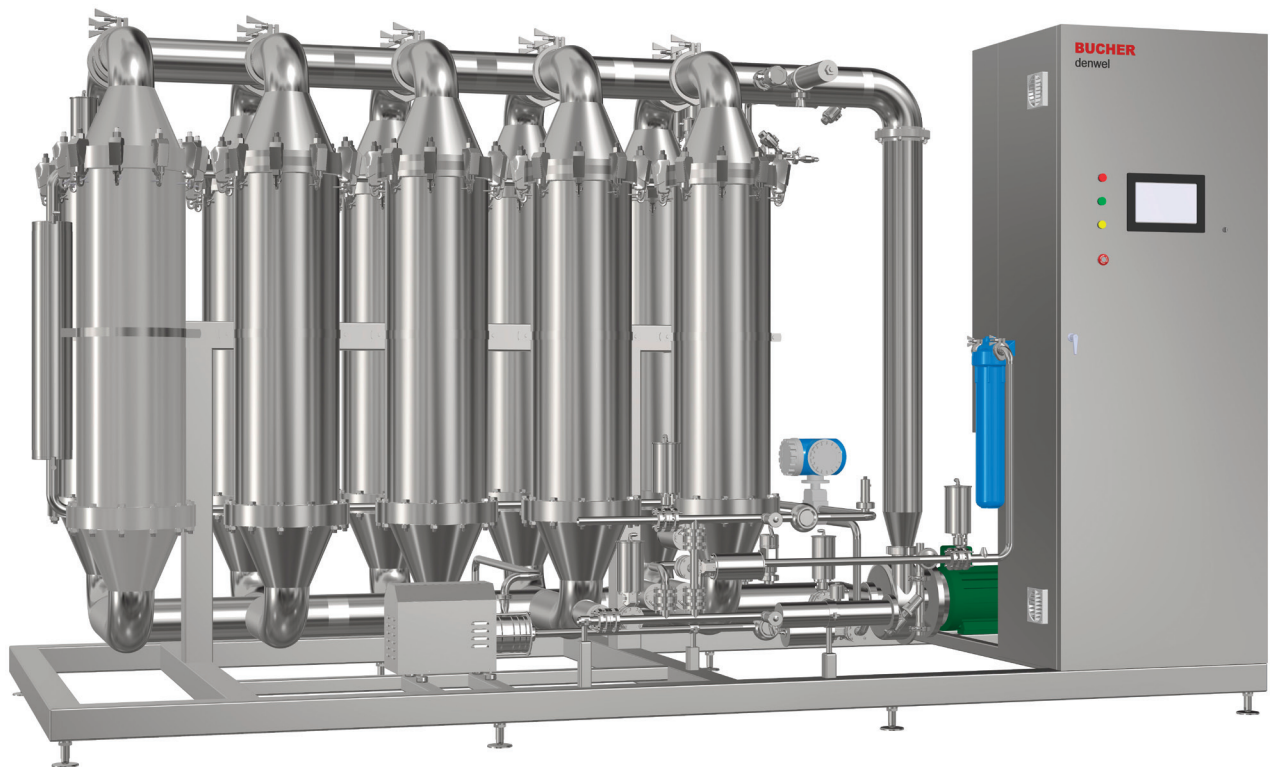

Kieselguhr free
beer filtration with
innovative filter
cartridges with organic
membranes

- Bright, yeast free filtered beer
- High flexibility for a wide range of beer types
- Longer average lifetime of membranes due to cartridge concept
- Easy expandability

The reliable solution for membrane filtration of beer

The technologies set up by Bucher Denwel ensure performance, reliability, short return of investment and sound operation profits.

Bucher Denwel presents Polynox MF, the reliable solution for industrial cross-flow beer filtration with innovative filter cartridges with polymeric membranes.

- Polynox MF filtration process for high-quality filtered beer and steady flow rates.
- High filtrate yield without solid waste.
- Flexible automation system with maximum operational safety thanks to permanent self-controlling devices.
- Plant sizes from 50 to 500 hl/h (22 – 220 gpm).

Module design

Stainless steel module holds up to 19 pcs of 2 m² filter cartridges BD20 which corresponds to approximate beer flow of 16 hl/h. Each filter cartridge is easy exchangeable and thus longer average lifetime of membranes is provided.

Membranes

Filter cartridges are filled with hydrophilic polyether sulfone (PES) membrane with asymmetrical structure specially adapted to beer. All materials are FDA approved.

The asymmetrical structure greatly contributes to maintaining a steady filtration flow rate. The membranes can be exposed to alkaline, acidic and oxidizing cleaning agents for reliable recovery of filtration performance.

Process flow diagram

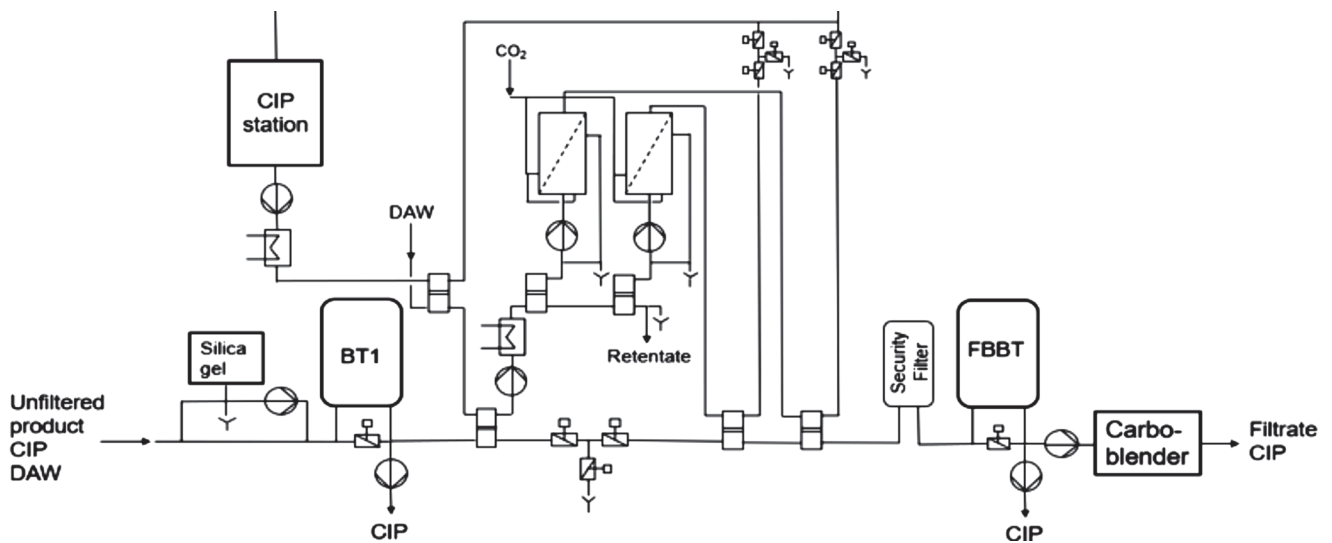

Bucher Denwel, spol. s r.o.
 K Hajum 2
 155 00 Praha
 Czech Republic
 +420 270 007 400
 sales@bucherdenwel.com
 bucherdenwel.com

Technical support
 +420 737 622 100
 service@bucherdenwel.com

Technical changes reserved.

Products

We develop and produce a wide range of specialized equipment and provide engineering solutions dedicated to help brewers to optimize their processes.

Combining experience and innovation we supply brewing equipment such as Filtration systems, Yeast plants, Water Deaeration, Blending, Carbonation, Dosing and Hard Seltzer systems, Dealcoholisation, CIP, Cold sterilisation, Flash Pasteurization and Beer tanks.

Services

We have a global presence. Our sales and service network is always available for you to provide consultancy, technical support and after sales service.